

tekmar® - Data Brochure

Difference Setpoint Control 157

D157

02/09

The Difference Setpoint Control 157 is designed to operate a variable speed pump to transfer heat from a heat source to a storage tank. Varying the speed of the pump provides fast and accurate temperature control to maintain the target temperature difference (ΔT). Additional minimum and maximum setpoints turn off the pump when heat transfer is no longer desirable. Potential applications include using solar collectors or a wood boiler as a heat source.

Additional functions include:

- 120 V (ac) powered pump outputs
- Second On/Off pump with 4 modes of operation
- Optional auxiliary sensor input to be used in heat dump and heat supplement modes
- Freeze Protection
- Displays total amount of energy transfer in BTU or kWh
- Certified to CSA and UL standards for use in the USA and Canada

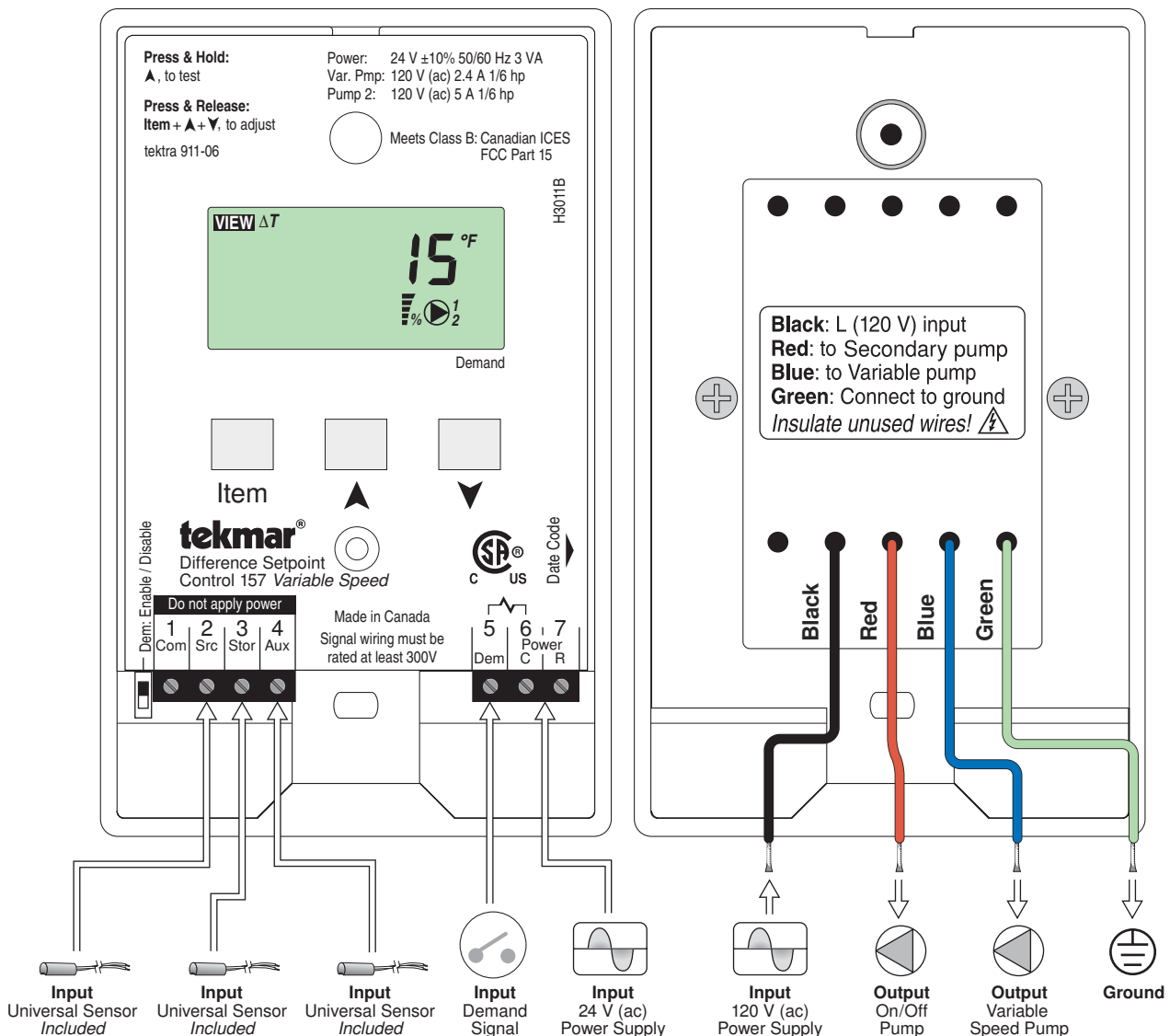

How to Use the Data Brochure

This brochure is organized into three main sections.

They are: 1) Sequence of Operation, 2) Installation, and 3) Control Settings

The Control Settings section of this brochure describes the various items that are adjusted and displayed by the control. The control functions of each adjustable item are described in the Sequence of Operation.

Table of Contents

User Interface	2	Installation	8
Display	3	Control Settings	10
Symbol Description.....	3	DIP Switch Settings.....	10
Sequence of Operation.....	4	VIEW Menu	11
Section A: General	4	ADJUST Menu	12
Section B: Modes of Operation	4	Test Routine.....	14
Section C: Targets and Differentials	5	Error Messages	15
Section D: Control Features	6	Technical Data	16
Section E: Energy Calculation.....	7	Limited Warranty	16

User Interface

The 157 uses a Liquid Crystal Display (LCD) as the method of supplying information. Use the LCD in order to set up and monitor the operation of your system. The 157 has three push buttons (Item, ▲, ▼) for selecting, viewing, and adjusting settings. When programming the control, record settings in the Adjust menu table which is found in the second half of this brochure.

Item

The selected item will be displayed using the segments available in the screen. To view the next available item, press and release the Item button. Once you have reached the last available item, pressing and releasing the Item button will return the display to the first item.



Adjust

To make an adjustment to a setting in the control, press and hold simultaneously for 1 second all three (3) buttons. The display will then show the word ADJUST in the top left corner. Select the desired item using the Item button. Finally, use the ▲ or ▼ button to make the adjustment.



Display

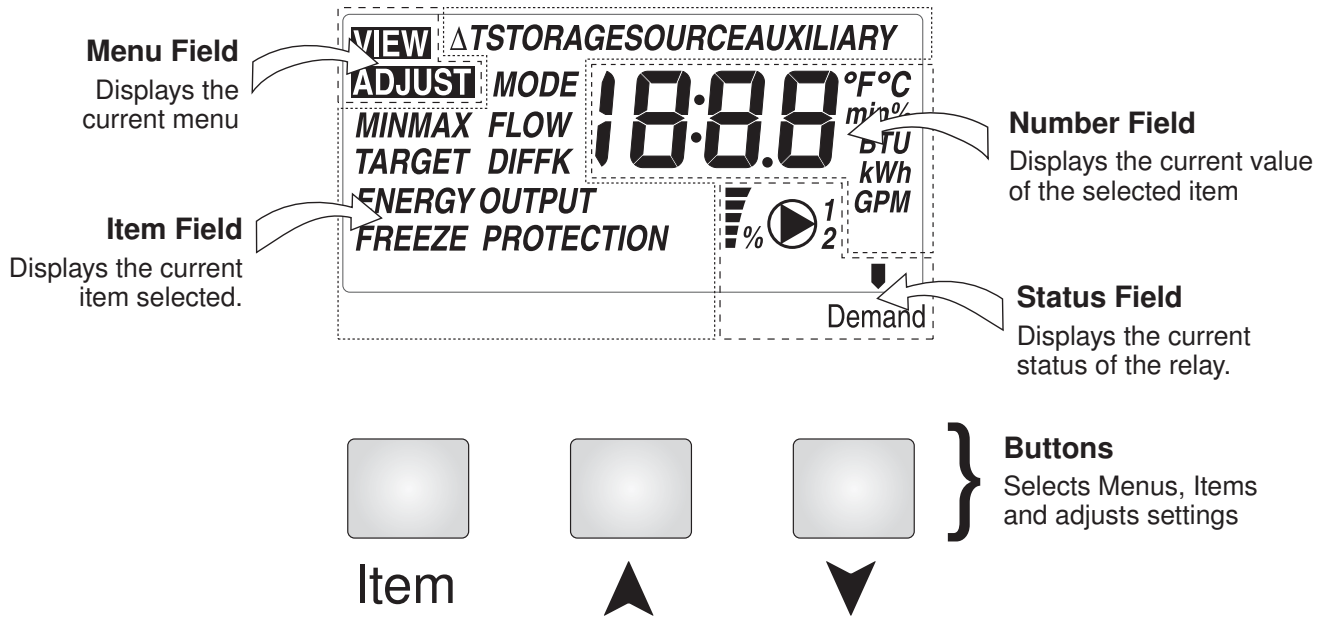

Symbol Description

ΔT	Delta T Displays the temperature difference between the source and storage sensors.	STORAGE	Storage Displays the temperature at the storage sensor.
SOURCE	Source Displays the temperature at the source sensor.	AUXILIARY	Auxiliary Displays the temperature at the auxiliary sensor.
MODE	Mode Displays the modes of operation for the on/off pump, P2.	MINMAX	Minimum and Maximum Displays the min and max sensor temperatures.
FLOW	Flow Displays the maximum flow rate of the variable speed pump.	TARGET	Target Displays any target.
DIFF	Differential Displays any differential.	K	Fluid Constant K Used to calculate heat transfer. Look up fluid constant in this data brochure.
ENERGY	Energy Displays the total number of BTU's or kWh's accumulated by the control's energy calculation.	OUTPUT	Output Displays the % output of variable speed pump. Each bar represents 20% output.
FREEZE PROTECTION	Freeze Protection Displays the status of the freeze protection function of the control.	$^{\circ}F, ^{\circ}C, min, \%$, BTU, kWh, GPM	Units of Measurement
	Pump Displays the status of the variable speed (1) and secondary (2) pump.		Demand Pointer Displays if a demand is applied to the control.

Sequence of Operation

Section A – General

Powering Up The Control

When the Difference Setpoint Control 157 is powered up, all segments are displayed in the LCD for 2 seconds, and then the type number is displayed for 2 seconds. Next, the software version is displayed for 2 seconds. Finally, the control enters into the normal operating mode and by default the LCD displays the current ΔT temperature.

Variable Speed Pump

A manufacturer approved wet rotor circulator is connected to the 157 at the back of the control (see Table 1 for approved pumps). The 157 increases or decreases the power output to the circulator to vary the speed and maintain the target difference setpoint temperature (ΔT) between the source and the storage sensors. As the ΔT increases, the pump speed increases and as the ΔT decreases, the pump speed decreases. The current % output of the variable speed pump is displayed in the view menu.

Table 1: Manufacturer approved pump models

Grundfos (F)				Taco				B & G			Armstrong			Wilo					
15-42	15-58	26-64	43-75	003	007	0010	0012	NRF 9	NRF 22	NRF 33	Astro			Star S16FX			Star		
**	***	**	***								25BU	30	50	*	**	***	S21FX	17FX	30F

*Speed 1, **Speed 2, ***Speed 3

These circulators have been tested and approved by the manufacturer for use with tekmar variable speed electronics.

Section B – Modes of Operation

The 157 has a second 120 V (ac) powered output wired through the back of the control for an on/off pump. The second pump has 4 adjustable modes of operation depending on the application.

Mode Off is for applications where the second pump is not used. The second pump relay is non-operational. Refer to application A157-1.

Mode 1 Heat Exchanger is for applications where the heat exchanger pump is needed to transfer heat between an external heat exchanger and the storage tank. The heat exchanger pump relay will operate whenever the variable speed pump is above 0% output. Refer to application A157-2.

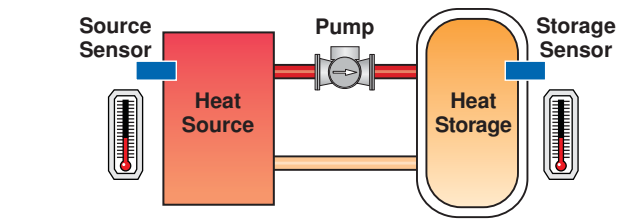
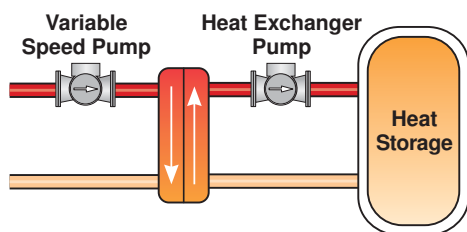

Turn On

When the variable speed pump turns on, it will operate at 100% output for an adjustable amount of time before operating at a variable speed starting at the minimum pump speed setting.

Turn Off

If the temperature differential falls below the ΔT target less the differential or below 1°F (.5°C), the variable speed pump will operate at the minimum pump speed for 2 minutes before shutting off. The minimum off time for the variable speed pump is fixed at 5 minutes.

Mode 2 Heat Supplement is for applications where the heat supplement pump transfers heat from a supplemental heat source (i.e. back-up boiler) to maintain the storage tank above the minimum storage target. The auxiliary sensor is optional in this mode. Install the auxiliary sensor in the upper portion of the storage tank. Refer to application A157-3.

If the boiler is not flow activated, the heat supplement pump output could provide a heat demand to another controller to turn on the boiler.

In this mode, the minimum on and off time for the heat supplement pump is fixed at 30 seconds.

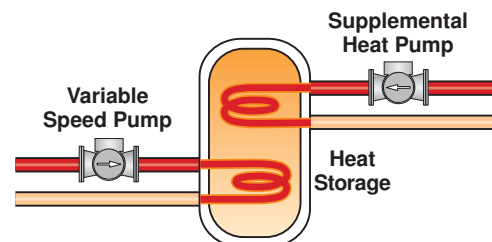

Mode 3 Heat Dump is for applications where an alternative heat sink can be utilized when the storage tank and collector are both above their maximum target. The variable speed pump turns off when the tank exceeds its max setpoint. The heat dump pump turns on when both the tank and collectors exceed their max setpoints. If during a heat dump the storage temperature falls below its maximum targets less differential, the heat dump pump relay is turned off and the variable speed pump is allowed to operate normally. The auxiliary sensor is optional in this mode. Install the auxiliary sensor in the heat dump. Refer to application A157-4.

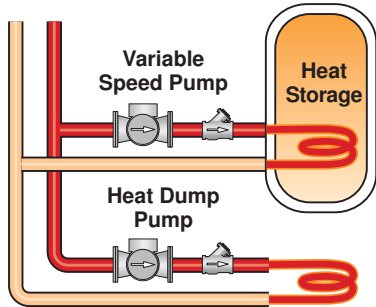

Mode 4 Booster Pump is for drain back applications where a booster pump is used to overcome high head upon system startup. When the ΔT rises above the ΔT target, the control turns on the booster pump and operates the variable speed pump at 100% output. After an adjustable time, the control turns off the booster pump and operates the variable speed pump above the minimum pump speed setting. Refer to application A157-5.

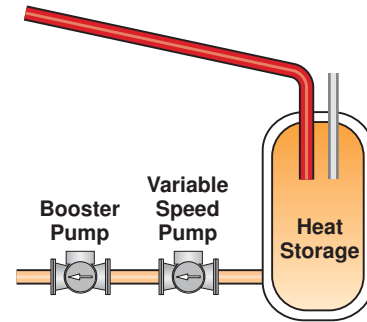

Table 2: Second Pump Mode Summary

MODE	NAME	DESCRIPTION	APPLICATION
Off	Off	Only the variable speed pump is operational.	A157-1
1	Heat Exchanger	Heat exchanger pump operates together with the variable speed pump.	A157-2
2	Heat Supplement	Heat supplement pump operates independently of the variable speed pump to maintain the storage tank at the minimum storage target.	A157-3
3	Heat Dump	Heat dump pump operates when the storage and source temperatures rise above their max targets to dump excess heat from the collectors.	A157-4
4	Booster Pump	Booster pump operates together with the variable speed pump at start up for an adjustable amount of time to overcome high head in drain back systems.	A157-5

Section C: Targets and Differentials

MAXIMUM SOURCE TARGET

(Mode = off, 1, 2, and 4)

If the source temperature rises above the maximum source target, the variable speed pump is turned off. In a drain back system, turning off the pump allows the fluid to drain back into a separate tank which protects the collectors from overheating. Ceasing operation may also protect equipment like the pump impeller from damage. The pump remains off until the source temperature falls below the maximum source target less differential.

(Mode = 3, Heat Dump)

In order for the heat dump pump to turn on, the storage temperature must be above the Maximum Storage Setpoint and the source temperature must be above the Maximum Source Setpoint. If the source or storage temperatures fall below their maximum targets less differential, the heat dump pump is turned off. The variable speed pump operates normally whenever the storage temperature falls below its maximum setpoint less differential. This setting ensures that the water being supplied to the heat dump is at least the Maximum Source Target temperature

Table 3: Outlines when the variable speed pump and heat dump pump are allowed to operate normally in mode 3.

Table 3	Scenario			
	1	2	3	4
Max Storage Setpoint	below	above	above	below
Max Source Setpoint	below	below	above	above
Variable Speed Pump	on	off	off	on
Heat Dump Pump	off	off	on	off

MINIMUM SOURCE TARGET

If the source temperature drops below the minimum source target, the variable speed pump is turned off. In a drain back system, turning off the pump allows the fluid to drain back into a separate tank which protects the collectors from freezing. The pump remains off until the source temperature rises above the minimum source target plus differential. This item is only available if freeze protection is turned off.

MAXIMUM STORAGE TARGET

If the storage temperature rises above the maximum storage target, the variable speed pump is turned off. This protects the tank from overheating by stopping the transfer of heat from the collectors. The pump remains off until the storage temperature falls below the maximum storage target less differential.

MINIMUM STORAGE TARGET

(Mode = 2, Heat Supplement)

This item is only available in Heat Supplement Mode 2. The heat supplement pump will operate independently of the variable speed pump to maintain the minimum storage target at the storage sensor, or optional auxiliary sensor if connected. If the temperature falls below the minimum storage target, the heat supplement pump will turn on and remain on until the temperature rises above the minimum storage target plus differential. This ensures that there is heat available in the storage tank for important loads like domestic hot water.

CAUTION: If storage is used for domestic hot water, anti-scald protection may be required by some local codes.

Figure 1 shows an example of how to set up the max and min storage targets and differentials.

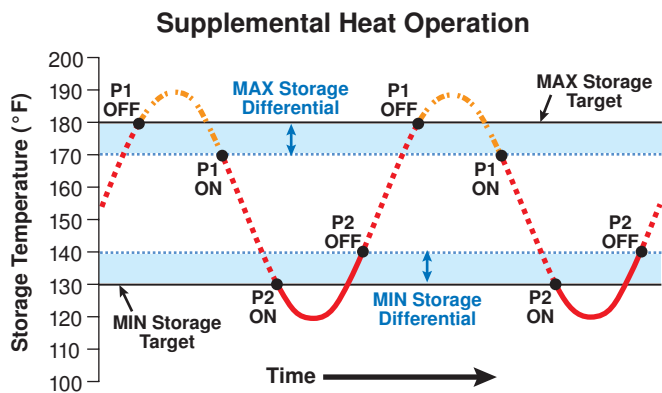

Figure 1: Turn on/off points for the variable speed pump (P1) and the heat supplement pump (P2) in mode 2, Heat Supplement. The min storage target is below the max storage target. Each have a 10°F (5.5°C) differential.

ΔT TARGET

The ΔT target is the turn on point for the variable speed pump. Once the ΔT rises above this target the variable speed pump will operate based on the minimum output (%), and maximum output (minutes) settings. The control will continue to vary the speed of the pump until the ΔT falls below the ΔT target less differential at which point the pump will run at the minimum output (%) for 2 minutes before turning off.

MAX AUXILIARY TARGET

This item is only available in Heat Dump Mode 3. If the auxiliary sensor temperature rises above the maximum auxiliary target, the heat dump pump is turned off. The heat dump pump remains off until the auxiliary sensor temperature drops below the maximum auxiliary target less differential. Using the auxiliary sensor will prevent the heat dump, like a pool or second tank, from overheating. There are no minimum on/off times for the heat dump pump.

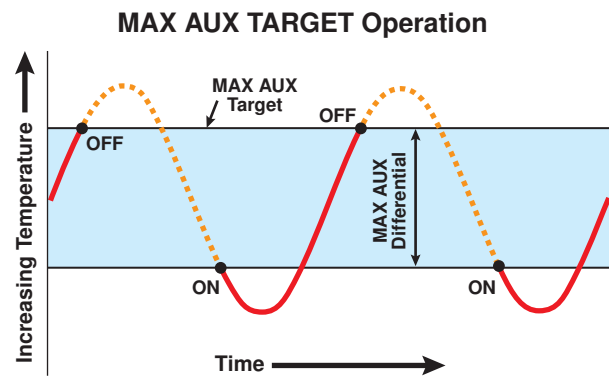

Figure 2: On and off points of the heat dump pump, using an auxiliary sensor in heat dump mode.

Section D – Control Features

FREEZE PROTECTION

If freeze protection is enabled and the source temperature falls below 35°F (2°C), the variable speed pump will operate at 100% output for twice as long as it takes the source temperature to increase to 40°F (4°C). This is limited to 20 minutes after source temperature reaches 40°F (4°C). This allows the water from the storage tank to reach the collectors AND flow back to the storage tank to provide freeze protection to ALL outdoor components. This item is only available if not in mode 4.

This item should only be turned on if:

- 1) other forms of freeze protection, like drain back, are not being used
- and
- 2) the heat transfer fluid in the collectors is 100% water
- and
- 3) the outdoor air temperature rarely falls below 35°F (2°C)

MINIMUM OUTPUT, %

This item selects the minimum speed the variable speed pump will run in order to avoid unwanted drain back when the pump is running at low speeds in a drain back system. At low speeds, some pumps stall and provide no flow. It is important to set the minimum pump speed above this stall point. This setting is adjustable between 0% and 100%. At 100% output the variable speed pump operates as an on/off pump.

MAXIMUM OUTPUT, minutes

When the variable speed pump turns on, it will operate at 100% output for this adjustable amount of time to overcome high head when filling a drain back system. If the control is in booster pump mode 4, the variable speed pump and the booster pump will operate together at 100% output for this adjustable amount of time.

This item can be used in drainback applications with or without a booster pump. Set this item to the time it takes the fluid to circulate through the collectors and into the drainback tank.

This item can also be used to prevent short cycling of the pump upon startup in non-drain back applications. When the variable speed pump turns on, the warm water in the collector passes by the source sensor causing its temperature to rise. Once all this water has passed, the cooler water in the pipe before the collector will pass by the source sensor causing the temperature to drop; potentially enough to lose the delta T and thus turn off the pump.

This sequence could happen a number of times before the system stabilizes and the variable speed pump runs continuously.

Setting the maximum pump speed (minutes) to the time it takes the fluid in the storage tank to reach the collectors will force the system to stabilize and thus reduce any short cycling of the pump at startup. This is especially important when the ambient outdoor temperature is very cool.

MONITORING TEMPERATURES

The control includes monitoring of minimum and maximum Source, Storage, and Auxiliary temperatures in the view menu. These items may be reset to their respective current sensor temperature by pressing and holding the ▲ and ▼ buttons simultaneously for 1 second while viewing the selected item. 'Clr' will then be displayed followed by the value being reset to its respective current sensor temperature when the buttons are released.

PUMP 2 RUNNING HOURS

The control includes monitoring of the second pump's running hours in the view menu where 1 count equals 1 hour. This item may be reset to zero by pressing and holding the ▲ and ▼ buttons simultaneously for 1 second while viewing this item. 'Clr' will then be displayed followed by the value being reset to zero when the buttons are released.

Section E – Energy Calculation

To calculate the amount of heat the system has transferred from the solar collectors to the storage tank, the control uses the following equation and displays ENERGY in the view menu in BTU's or kWh:

$$\text{Total Heat Transferred} = (\% \Delta T \text{ hours}) \times (\text{Flow}) \times K$$

Where:

- %ΔT hours is calculated by the control.
- Flow is the amount of fluid the variable speed pump moves through the system in US Gallons per minute.
- K is a fluid constant to be programmed in the adjust menu.

K

K is a constant calculated by multiplying the properties of the fluid; specific heat (BTU/lbm °F) by density (lbm/USGal) by 60 (min/hr). For example, 100% water has a specific heat of 1 BTU/lbm °F and a density of 8.33 lbm/USGal. Therefore the value of K in this case is $1 \times 8.33 \times 60 = 500$.

The value of K depends on the percent of glycol added to the heat transfer fluid. Select an appropriate K value from table 1 and program it into the adjust menu. If 100% water is used, select K = 500.

Table 4: K values for different heat transfer solutions based on % glycol.

Ethylene Glycol Solution			Propylene Glycol Solution		
%	Freezing Point (°F)	K @ 40°F	%	Freezing Point (°F)	K @ 40°F
0	32	500	0	32	500
10	23	492	10	26	495
20	14	483	20	18	489
30	2	471	30	7	480
40	-13	453	40	-8	463
50	-36	433	50	-29	443
60	-70	412	60	-55	422

FLOW

In the adjust menu, enter the actual flow rate of the variable speed pump operating at 100% output in US Gallons per minute (GPM).

Note: BTU = British Thermal Unit
lbm = Pound Mass
USGal = US Gallon
GPM = Gallon Per Minute

Installation

⚠ Caution ⚠

Improper installation and operation of this control could result in damage to the equipment and possibly even personal injury. It is your responsibility to ensure that this control is safely installed according to all applicable codes

and standards. This electronic control is not intended for use as a primary limit control. Other controls that are intended and certified as safety limits must be placed into the control circuit.

Step One — Getting Ready

Check the contents of this package. If any of the contents listed are missing or damaged, please contact your wholesaler or tekmar sales representative for assistance.

Type 157 includes: One Difference Setpoint Control 157, Two Universal Sensors 071, Data Brochures D 157, D 070, D 001, Application Brochure A 157.

Note: Carefully read the details of the Sequence of Operation to ensure that you have chosen the proper control for your application.

Step Two — Mounting

The control is mounted in accordance with the instructions in the Data Brochure D 001.

⚠ Step Three — Rough-in Wiring

The variable speed pump and second pump wiring terminates in the electrical box. All other wiring terminates in the two wiring chambers on the control. Determine whether the low voltage wiring enters the wiring chamber through the back or the bottom of the control. The wiring is roughed-in to the electrical box prior to installation of the control (see Brochure D 001). Standard 18 AWG solid wire is recommended for all low voltage wiring, and multi-strand 16 AWG wire is recommended for 120 V (ac) wiring.

Power must not be applied to any of the wires during the rough-in wiring stage.

- Install the Source Sensor 071 and Storage Sensor 071 according to the instructions in the Data Brochure D 070, and run the wiring back to the control.
- Run wires from the 24 V (ac) power to the control. Use a clean power source to ensure proper operation.

⚠ Step Four — Testing the Wiring

No wires should be connected to the control during testing.

The following tests are to be performed using standard testing practices and procedures, and should only be carried out by properly trained and experienced persons.

A good quality electrical test meter, capable of reading from at least 0 - 300 V (ac) and at least 0 - 2,000,000 Ohms, is essential to properly test the wiring and sensors.

Test the Sensors

In order to test the sensors, the actual temperature at each sensor location must be measured. A good quality digital thermometer with a surface temperature probe is recommended for ease of use and accuracy. Where a

digital thermometer is not available, a spare sensor can be strapped alongside the one to be tested, and the readings compared. Test the sensors according to the instructions in the Data Brochure D 070.



Test the Power Supply

Make sure exposed wires and bare terminals are not in contact with other wires or grounded surfaces. Turn on the power and measure the voltage across the 24 V (ac) power supply with an AC voltmeter. The reading should be between 20 and 28 V (ac).

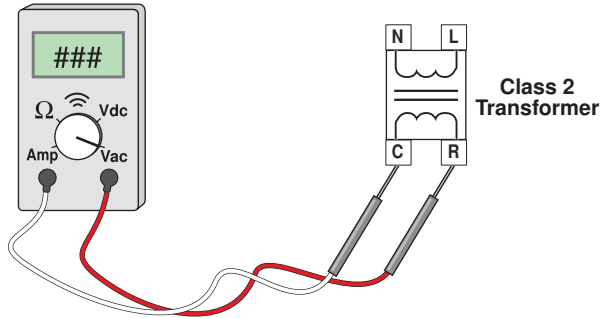

Step Five — Electrical Connections to the Control

The installer should test to confirm that no voltage is present at any of the wires.

Powered Input Connections

24 V (ac) Power

Connect the 24 V (ac) power supply to the Power C and Power R terminals (6 and 7). This connection provides power to the microprocessor and display of the control.

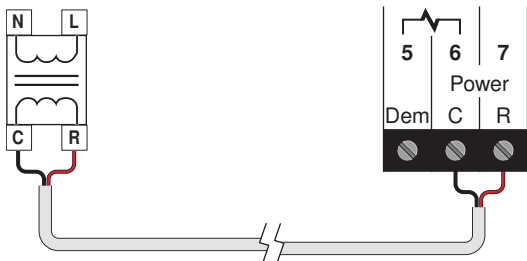

Enable/Disable Demand

To generate a demand, terminal 5 must be connected to terminal 7 (R) through a switching device.

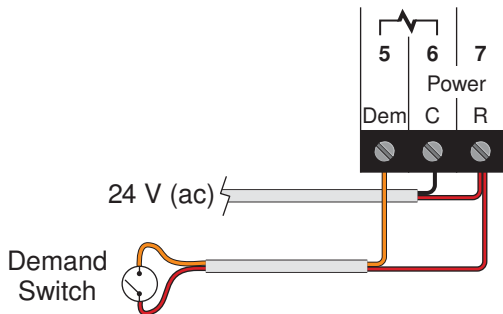

Output Connections

Variable Speed Pump

The 157 can vary the speed of a permanent capacitor, impedance protected, or equivalent pump motor that has a locked rotor current of less than 2.4A. Most small wet rotor circulators are suitable as described in table 1. The 157 has an internal overload protection circuit which is rated at

Test the Outputs

Variable Speed and Second Pump

Connect the power supply L and N directly to each pump and use the panel breaker switch to test for 100% output. If the pump does not operate, check the wiring and refer to any installation or troubleshooting information supplied with the pump. If the pump operates properly, turn off the power at the breaker and follow wiring instructions to provide power through the control.

2.5A 250V (ac). Contact your tekmar sales representative for details on the repair procedures if this circuit is blown.

Connect one of the wires from the variable speed pump to the blue wire at the back of the control. Connect the black wire from the back to the live (L) side of the 120 V (ac) power source. The other wire on the variable speed injection pump must be connected to the neutral (N) side of the 120 V (ac) power supply. Connect the green wire on the back of the control to ground.

Second Pump

Connect one of the wires from the Second pump to the red wire at the back of the control. Connect the black wire from the back of the control to the live (L) side of the 120 V (ac) power source if not already connected. The other wire on the Second pump must be connected to the neutral (N) side of the 120 V (ac) power supply. Connect the green wire on the back of the control to ground if not already connected.

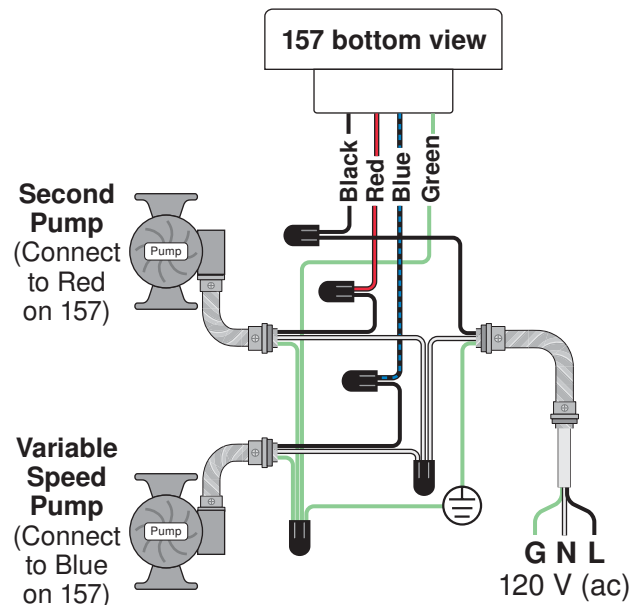

Sensor and Un-powered Input Connections

Do not apply power to these terminals as this will damage the control.

Source Sensor

Connect the two wires from the Source Sensor 071 to the Com and Src terminals (1 and 2). The Source Sensor is used by the 157 to measure the solar collector temperature.

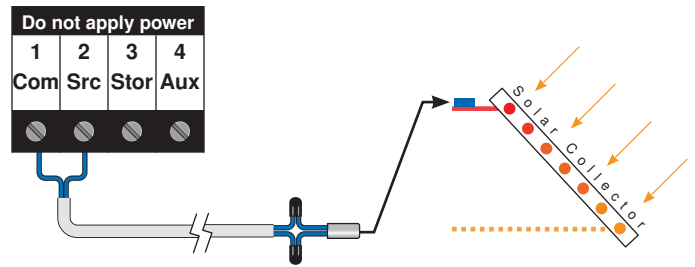

Storage Sensor

Connect the two wires from the Storage Sensor 071 to the Com and Stor terminals (1 and 3). The Storage Sensor is used by the 157 to measure the Storage tank temperature.

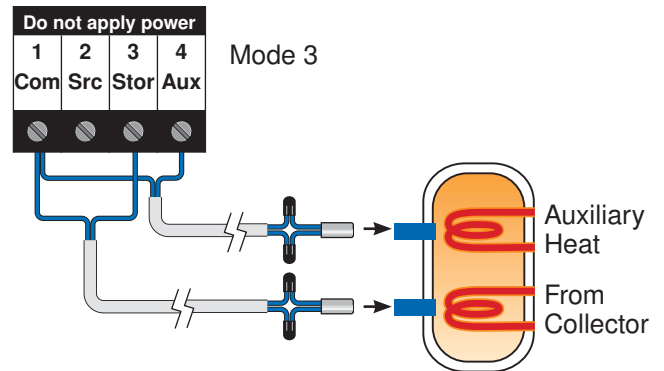

Auxiliary Sensor

The auxiliary sensor can only be used when the control is in either mode 3, heat supplement, or mode 4, heat dump. The 157 will auto detect when an auxiliary sensor is wired to terminals 1 and 4.

Connect two wires from the Auxiliary Sensor 071 to the Com and Aux terminals (1 and 4). The Auxiliary Sensor is used by the 157 to measure either the heat dump temperature or the upper storage tank temperature.

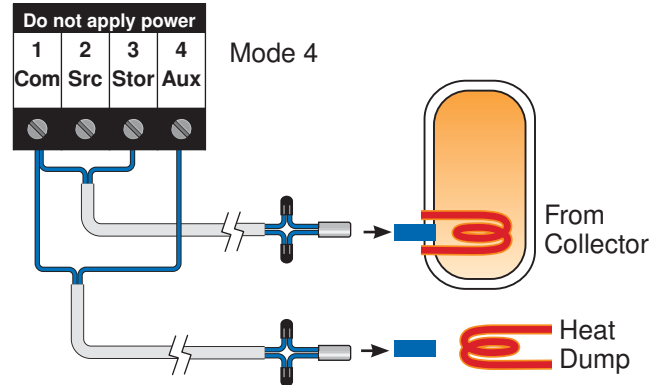

Control Settings

DIP Switch Settings

Demand: Enable / Disable

The Enable / Disable DIP switch is used to select whether the demand will enable or disable the control. If a demand is present, a pointer will be displayed at the bottom right hand corner of the LCD pointing to the word Demand. Applying a demand resets any minimum on/off times.

If Enable is selected, the outputs will remain off until the demand is powered and the control is enabled, allowing the outputs to operate normally.

If Disable is selected, the outputs will operate normally until the demand is powered and the control is disabled, turning off all outputs.

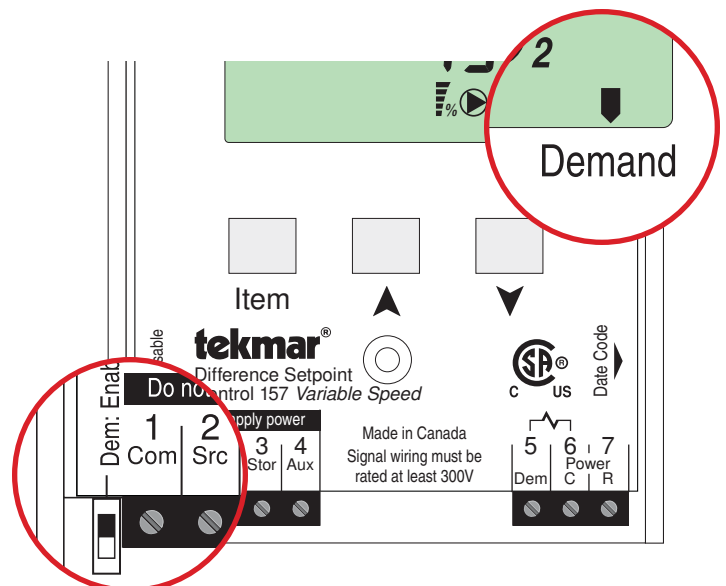

Display Menus

View Menu (1 of 2)

View Next Item



Item

The View menu items display current operating temperatures and system status information. Use the Item button to view items in this menu.

VIEW MENU

Item Field	Range	Description
VIEW ΔT 10 ^{°F}	-99 to 300°F (-73 to 149°C)	DELTA T Current temperature difference between the source and storage sensors.
VIEW ΔT TARGET 10 ^{°F}	2 to 90°F (1 to 50°C)	DELTA T TARGET The target temperature difference between the source and storage sensors as programmed in the adjust menu.
VIEW SOURCE 150 ^{°F}	-30 to 300°F (-34 to 149°C)	SOURCE TEMPERATURE Current source temperature as measured by the source sensor.
VIEW STORAGE 140 ^{°F}	-30 to 300°F (-34 to 149°C)	STORAGE TEMPERATURE Current storage temperature as measured by the storage sensor.
VIEW AUXILIARY 120 ^{°F}	-30 to 300°F (-34 to 149°C)	AUXILIARY TEMPERATURE Current auxiliary temperature as measured by the auxiliary sensor. Note: this item is only available if the auxiliary sensor is connected to the control.
VIEW SOURCE MAX 160 ^{°F}	-30 to 300°F (-34 to 149°C)	SOURCE MAXIMUM Maximum source temperature since this item was last cleared. To clear, press and hold the up and down buttons for 1 second.
VIEW SOURCE MIN 40 ^{°F}	-30 to 300°F (-34 to 149°C)	SOURCE MINIMUM Minimum source temperature since this item was last cleared. To clear, press and hold the up and down buttons for 1 second.
VIEW STORAGE MAX 180 ^{°F}	-30 to 300°F (-34 to 149°C)	STORAGE MAXIMUM Maximum storage temperature since this item was last cleared. To clear, press and hold the up and down buttons for 1 second.
VIEW STORAGE MIN 130 ^{°F}	-30 to 300°F (-34 to 149°C)	STORAGE MINIMUM Minimum storage temperature since this item was last cleared. To clear, press and hold the up and down buttons for 1 second.
VIEW AUXILIARY MAX 176 ^{°F}	-30 to 300°F (-34 to 149°C)	AUXILIARY MAXIMUM Maximum auxiliary temperature since this item was last cleared. To clear, press and hold the up and down buttons for 1 second. Note: this item is only available if the auxiliary sensor is connected to the control.

Continued on next page.

View Menu (2 of 2)

VIEW MENU

Item Field	Range	Description
	-30 to 300 °F (-34 to 149 °C)	AUXILIARY MINIMUM Minimum auxiliary temperature since this item was last cleared. To clear, press and hold the up and down buttons for 1 second. Note: this item is only available if the auxiliary sensor is connected to the control.
	0 to 100%	PUMP SPEED Current % output of the variable speed pump.
	0 to 1,999,999 BTU or kWh	ENERGY TRANSFER Total amount of BTU's or kWh's transferred from the source to the storage since this item was last cleared. To clear, press and hold the up and down buttons for 1 second. 1 count = 1000 BTU.
	0 to 1,999,999 hours	PUMP 2 RUNNING HOURS The total running time of pump 2 since this item was last cleared. To clear this item, press and hold the up and down buttons for one second. 1 count = 1 hour.

After the last item, the control returns to the first item in the menu.

Adjust Menu (1 of 3)

Enter Adjust Menu

Item

Next Item

Item

Change Value

The Program menu items are the programmable settings used to operate the system. **Press and hold all three buttons simultaneously** to enter the Program menu.

ADJUST MENU

Item Field	Range	Description	Actual Setting
	OFF, 1, 2, 3, 4 Default = OFF	MODE Mode of operation for Second pump, P2. Mode 1 = Heat Exchanger, Mode 2 = Heat Supplement, Mode 3 = Heat Dump, Mode 4 = Booster Pump	
	2 to 90 °F (1 to 50 °C) Default = 15 °F (8 °C)	DELTA T TARGET The variable speed pump, P1, will try to maintain the temperature difference between the source and storage at this target.	
	2 to 45 °F (1 to 25 °C) Default = 10 °F (5.5 °C)	DELTA T DIFFERENTIAL When the delta T drops this differential below the delta T target the variable speed pump, P1, will run at the minimum % output for 2 minutes then turn off.	
	50 to 200 °F (10 to 93 °C) Default = 180 °F (82 °C)	MAXIMUM STORAGE TARGET If the storage temperature rises above this maximum target, the variable speed pump is turned off.	

Continued on next page.

Adjust Menu (2 of 3)

ADJUST MENU

Item Field	Range	Description	Actual Setting
<p>STORAGE</p> <p>ADJUST MAX DIFF</p> <p>10^{°F}</p>	<p>2 to 45°F (1 to 25°C) Default = 10°F (5.5°C)</p>	<p>MAXIMUM STORAGE DIFFERENTIAL</p> <p>The variable speed pump will turn back on when the storage temperature falls this differential below the Max Storage Target.</p>	
<p>STORAGE</p> <p>ADJUST MIN TARGET</p> <p>140^{°F}</p>	<p>70 to 190°F (21 to 88°C) Default = 140°F (60°C)</p>	<p>MINIMUM STORAGE TARGET (Mode 2)</p> <p>The supplemental heat pump, P2, will turn on when the storage temperature falls below this target. Optional Auxiliary Sensor.</p>	
<p>STORAGE</p> <p>ADJUST MIN DIFF</p> <p>10^{°F}</p>	<p>2 to 45°F (1 to 25°C) Default = 10°F (5.5°C)</p>	<p>MINIMUM STORAGE DIFFERENTIAL (Mode 2)</p> <p>The supplemental heat pump will turn off when the storage temperature rises this differential above the Min Storage Target. Optional Auxiliary Sensor.</p>	
<p>SOURCE</p> <p>ADJUST MAX TARGET</p> <p>OFF</p>	<p>190 to 260°F, OFF (88 to 127°C, OFF Default = OFF</p>	<p>MAXIMUM SOURCE TARGET</p> <p>In order for the heat dump pump to turn on in heat dump mode, the source and storage temperatures must be above the Maximum Source and Storage Targets respectively.</p>	
<p>SOURCE</p> <p>ADJUST MAX DIFF</p> <p>10^{°F}</p>	<p>2 to 45°F (1 to 25°C) Default = 10°F (5.5°C)</p>	<p>MAXIMUM SOURCE DIFFERENTIAL (Maximum Source Target ≠ Off)</p> <p>The heat dump pump will turn off when the storage temperature falls this differential below the Maximum Source Target.</p>	
<p>SOURCE</p> <p>ADJUST MIN TARGET</p> <p>OFF</p>	<p>OFF, 50 to 185°F (OFF, 10 to 85°C) Default = OFF</p>	<p>MINIMUM SOURCE TARGET</p> <p>If the source temperature drops below this setpoint the injection pump is turned off</p>	
<p>SOURCE</p> <p>ADJUST MIN DIFF</p> <p>10^{°F}</p>	<p>2 to 45°F (1 to 25°C) Default = 10°F (5.5°C)</p>	<p>MINIMUM SOURCE DIFFERENTIAL (Min Source Target ≠ Off)</p> <p>The variable speed pump will turn back on when the source temperature rises this differential above the Minimum Source Target.</p>	
<p>AUXILIARY</p> <p>ADJUST MAX TARGET</p> <p>100^{°F}</p>	<p>50 to 220°F (10 to 104°C) Default = 100°F (38°C)</p>	<p>MAXIMUM AUXILIARY TARGET (Mode 3)</p> <p>The heat dump pump will turn off when the auxiliary temperature rises above this target.</p>	
<p>AUXILIARY</p> <p>ADJUST MAX DIFF</p> <p>10^{°F}</p>	<p>2 to 45°F 1 to 25°C Default = 10°F (5.5°C)</p>	<p>MAXIMUM AUXILIARY DIFFERENTIAL (Mode 3)</p> <p>The heat dump pump will turn on when the auxiliary temperature falls this differential below the Maximum Auxiliary Target.</p>	
<p>FREEZE PROTECTION</p> <p>ADJUST</p> <p>OFF</p>	<p>ON, OFF Default = OFF</p>	<p>FREEZE PROTECTION (Mode ≠ 4)</p> <p>If the source temperature falls below 35°F (2°C), the variable speed pump will turn on at 100% output until the source temperature rises to 40°F (4°C).</p>	

Continued on next page.

Adjust Menu (3 of 3)

ADJUST MENU

Item Field	Range	Description	Actual Setting
	0% to 100% Default = 0%	MINIMUM OUTPUT, % Minimum pump speed for the variable speed pump to prevent unwanted drainback at low speeds. At 100% Output, the pump operates as an On/Off pump.	
	OFF, 0:10 to 10:00 minutes Default = 3:00 Min	MAXIMUM OUTPUT, MINUTES Time the variable speed pump operates at 100% output upon startup to fill a drainback system. If in Mode 4, Booster Pump, this is also the time the booster pump will run upon startup.	
	400 to 500 Default = 500	K Fluid constant to be used to calculate total energy transfer in BTU's or kWh.	
	0 to 45 GPM Default = 5.0	MAXIMUM FLOW The actual flowrate of the variable speed pump, P1, at 100% output. Used to calculate the total energy transfer in BTU's. (Depends on head, see pump curve or measure independently).	
	°F, °C Default = °F	UNITS Pressing the up or down button on this item changes the units of measure for the control between Celsius and Fahrenheit.	
		ESCAPE This item exits the ADJUST menu by pressing either the up or down button.	

After the last item, the control returns to the first item in the menu.

Field Test

Press and hold the up button for 3 seconds to enter the test routine. The number field will display tSt until the button is released and then the test routine will begin.

Step 1: The variable speed pump ramps up to 100% over 10 seconds.

Step 2: The variable speed pump ramps down to 0% over 10 seconds.

Step 3: The second pump turns on for 10 seconds.

Once step 3 is completed the test routine is finished. The control will then resume normal operation.

The test routine can be paused at any time by pressing the up button during any of the 3 steps. This is important so that the installer can fill the system or check to see where the stall point is or check the operation of the second pump. If the test is paused for 24 hours, the control will exit the test routine and resume normal operation.

The down button can be pressed during step 1 to toggle on and off P2. The down button can be pressed during step 3 to turn off the second pump and exit the test routine. This test sequence is only available in the View menu.

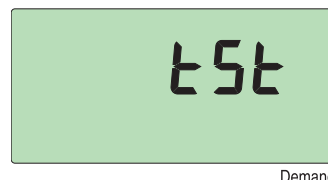

Demand



Item



Error Messages

All errors are latching. If the error condition has been repaired, the control will continue to operate normally. The error message can be manually cleared by pressing the item button.

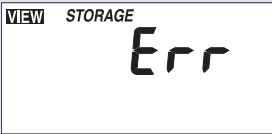
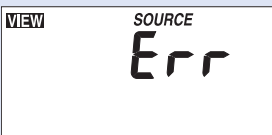
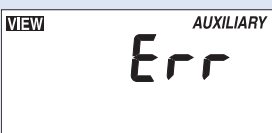
	<p>EEPROM READ ERROR</p> <p>The control was unable to read a piece of information from its EEPROM. This error can be caused by a noisy power source. The control will load the factory defaults and stop operation until all the settings are verified. To clear, view all items in the ADJUST menu.</p>
	<p>STORAGE SENSOR ERROR</p> <p>The control is no longer able to read the Storage Sensor due to an open or short circuit. Locate and repair the problem as described in the Data Brochure D070. The relays will remain off until the error is cleared and the 5 minute minimum off time has elapsed.</p>
	<p>SOURCE SENSOR ERROR</p> <p>The control is no longer able to read the Source Sensor due to an open or short circuit. Locate and repair the problem as described in the Data Brochure D070. The relays will remain off until the error is cleared and the 5 minute minimum off time has elapsed. If freeze protection is enabled, the relays will remain on as a fail safe.</p>
	<p>AUXILIARY SENSOR ERROR</p> <p>The control is no longer able to read the Auxiliary Sensor due to an open or short circuit. Locate and repair the problem as described in the Data Brochure D070. The relays will remain off until the error is cleared.</p>

Technical Data

Difference Setpoint Control 157 Variable Speed

Literature	— D 157, A 157, D001, D070
Control	— Microprocessor control; This is not a safety (limit) control
Packaged weight	— 1.5 lb. (670 g)
Dimensions	— Enclosure C, White PVC Plastic
Approvals	— 4-3/4" H x 2-7/8" W x 7/8" D (120 x 74 x 22 mm)
Approvals	— CSA C US, CSA 22.2 N°24 and UL 873, meets class B: ICES & FCC Part 15
Ambient conditions	— Indoor use only, -20 to 120°F (-30 to 50°C), < 90% RH non-condensing
Power supply	— 24 V (ac) ±10%, 50/60 Hz, 3 VA
Var. Pump	— 120 V (ac) 2.4 A 1/6 hp, fuse T2.5 A 250 V
Pump 2	— 120 V (ac) 5 A 1/6 hp
Demand	— 24 V (ac) 2 VA
Sensors included:	— NTC thermistor, 10 kΩ @ 77°F (25°C ±0.2°C) β=3892 — 2 of Universal Sensor 071

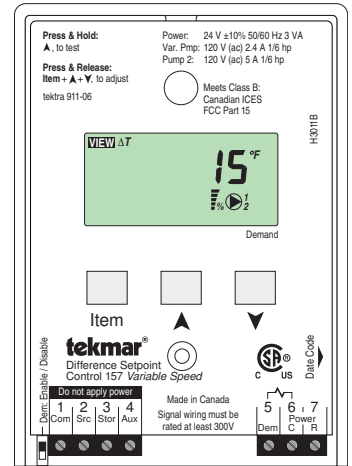

Limited Warranty and Product Return Procedure

Limited Warranty *The liability of tekmar under this warranty is limited. The Purchaser, by taking receipt of any tekmar product ("Product"), acknowledges the terms of the Limited Warranty in effect at the time of such Product sale and acknowledges that it has read and understands same.*

The tekmar Limited Warranty to the Purchaser on the Products sold hereunder is a manufacturer's pass-through warranty which the Purchaser is authorized to pass through to its customers. Under the Limited Warranty, each tekmar Product is warranted against defects in workmanship and materials if the Product is installed and used in compliance with tekmar's instructions, ordinary wear and tear excepted. The pass-through warranty period is for a period of twenty-four (24) months from the production date if the Product is not installed during that period, or twelve (12) months from the documented date of installation if installed within twenty-four (24) months from the production date.

The liability of tekmar under the Limited Warranty shall be limited to, at tekmar's sole discretion: the cost of parts and labor provided by tekmar to repair defects in materials and/or workmanship of the defective product; or to the exchange of the defective product for a warranty replacement product; or to the granting of credit limited to the original cost of the defective product, and such repair, exchange or credit shall be the sole remedy available from tekmar, and, without limiting the foregoing in any way, tekmar is not responsible, in contract, tort or strict product liability, for any other losses, costs, expenses, inconveniences, or damages, whether direct, indirect, special, secondary, incidental or consequential, arising from ownership or use of the product, or from defects in workmanship or materials, including any liability for fundamental breach of contract.

The pass-through Limited Warranty applies only to those defective Products returned to tekmar during the warranty period. This Limited Warranty does not cover the cost of the parts or labor to remove or transport the defective Product, or to reinstall the repaired or replacement Product, all such costs and expenses being subject to Purchaser's agreement and warranty with its customers.

Any representations or warranties about the Products made by Purchaser to its customers which are different from or in excess of the tekmar Limited Warranty are the Purchaser's sole responsibility and obligation. Purchaser shall indemnify and hold tekmar harmless from and against any and all claims, liabilities and damages of any kind or nature which arise out of or are related to any such representations or warranties by Purchaser to its customers.

The pass-through Limited Warranty does not apply if the returned Product has been damaged by negligence by persons other than tekmar, accident, fire, Act of God, abuse or misuse; or has been damaged by modifications, alterations or attachments made subsequent to purchase which have not been authorized by tekmar; or if the Product was not installed in compliance with tekmar's instructions and/or the local codes and ordinances; or if due to defective installation of the Product; or if the Product was not used in compliance with tekmar's instructions.

THIS WARRANTY IS IN LIEU OF ALL OTHER WARRANTIES, EXPRESS OR IMPLIED, WHICH THE GOVERNING LAW ALLOWS PARTIES TO CONTRACTUALLY EXCLUDE, INCLUDING, WITHOUT LIMITATION, IMPLIED WARRANTIES OF MERCHANTABILITY AND FITNESS FOR A PARTICULAR PURPOSE, DURABILITY OR DESCRIPTION OF THE PRODUCT, ITS NON-INFRINGEMENT OF ANY RELEVANT PATENTS OR TRADEMARKS, AND ITS COMPLIANCE WITH OR NON-VIOLATION OF ANY APPLICABLE ENVIRONMENTAL, HEALTH OR SAFETY LEGISLATION; THE TERM OF ANY OTHER WARRANTY NOT HEREBY CONTRACTUALLY EXCLUDED IS LIMITED SUCH THAT IT SHALL NOT EXTEND BEYOND TWENTY-FOUR (24) MONTHS FROM THE PRODUCTION DATE, TO THE EXTENT THAT SUCH LIMITATION IS ALLOWED BY THE GOVERNING LAW.

Product Warranty Return Procedure All Products that are believed to have defects in workmanship or materials must be returned, together with a written description of the defect, to the tekmar Representative assigned to the territory in which such Product is located. If tekmar receives an inquiry from someone other than a tekmar Representative, including an inquiry from Purchaser (if not a tekmar Representative) or Purchaser's customers, regarding a potential warranty claim, tekmar's sole obligation shall be to provide the address and other contact information regarding the appropriate Representative.

tekmar[®]
Control Systems

tekmar Control Systems Ltd., Canada
tekmar Control Systems, Inc., U.S.A.
**Head Office: 5100 Silver Star Road
Vernon, B.C. Canada V1B 3K4
(250) 545-7749 Fax. (250) 545-0650
Web Site: www.tekmarcontrols.com**

