

tekmar® - Application

Difference Setpoint Control 155

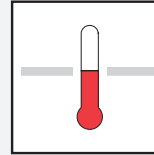

A 155-1
09/94

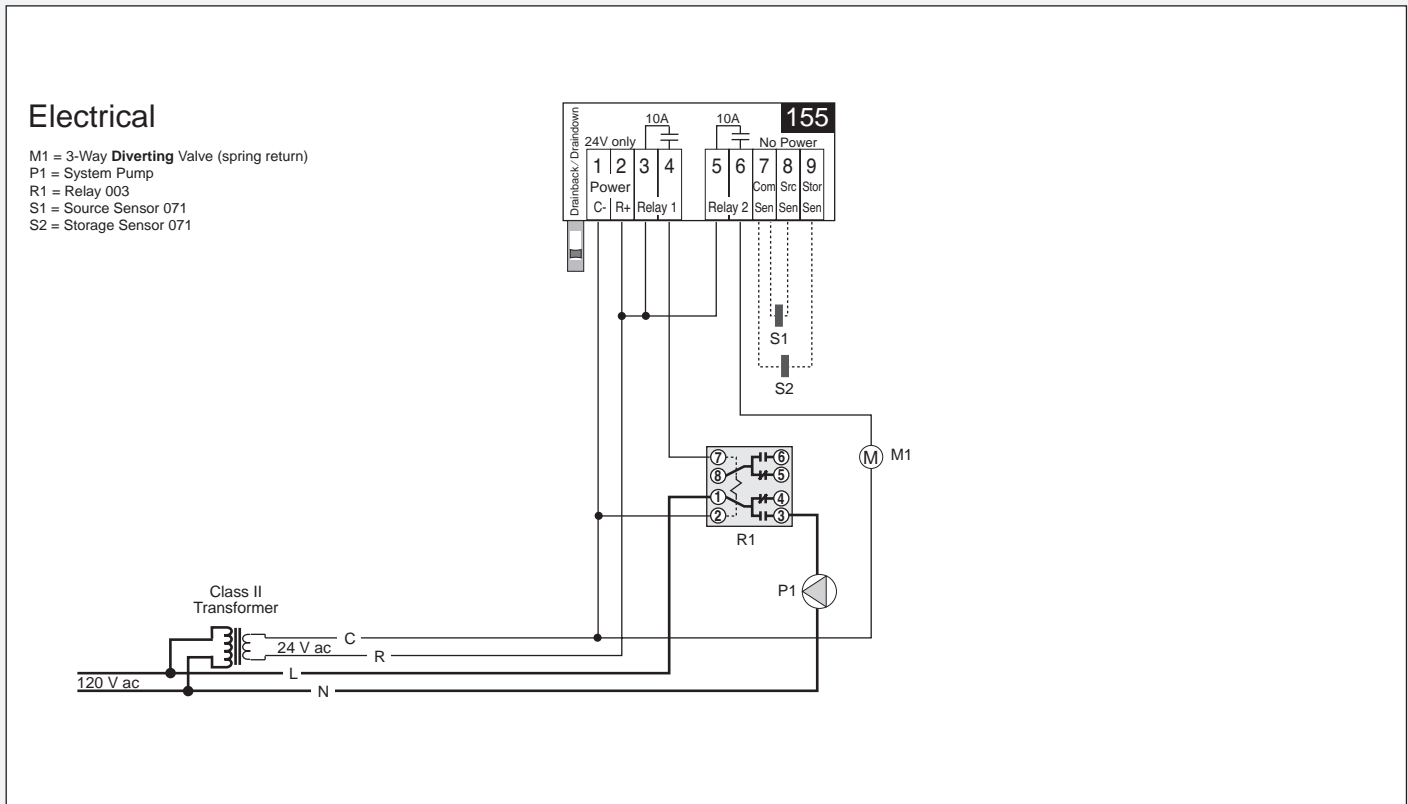
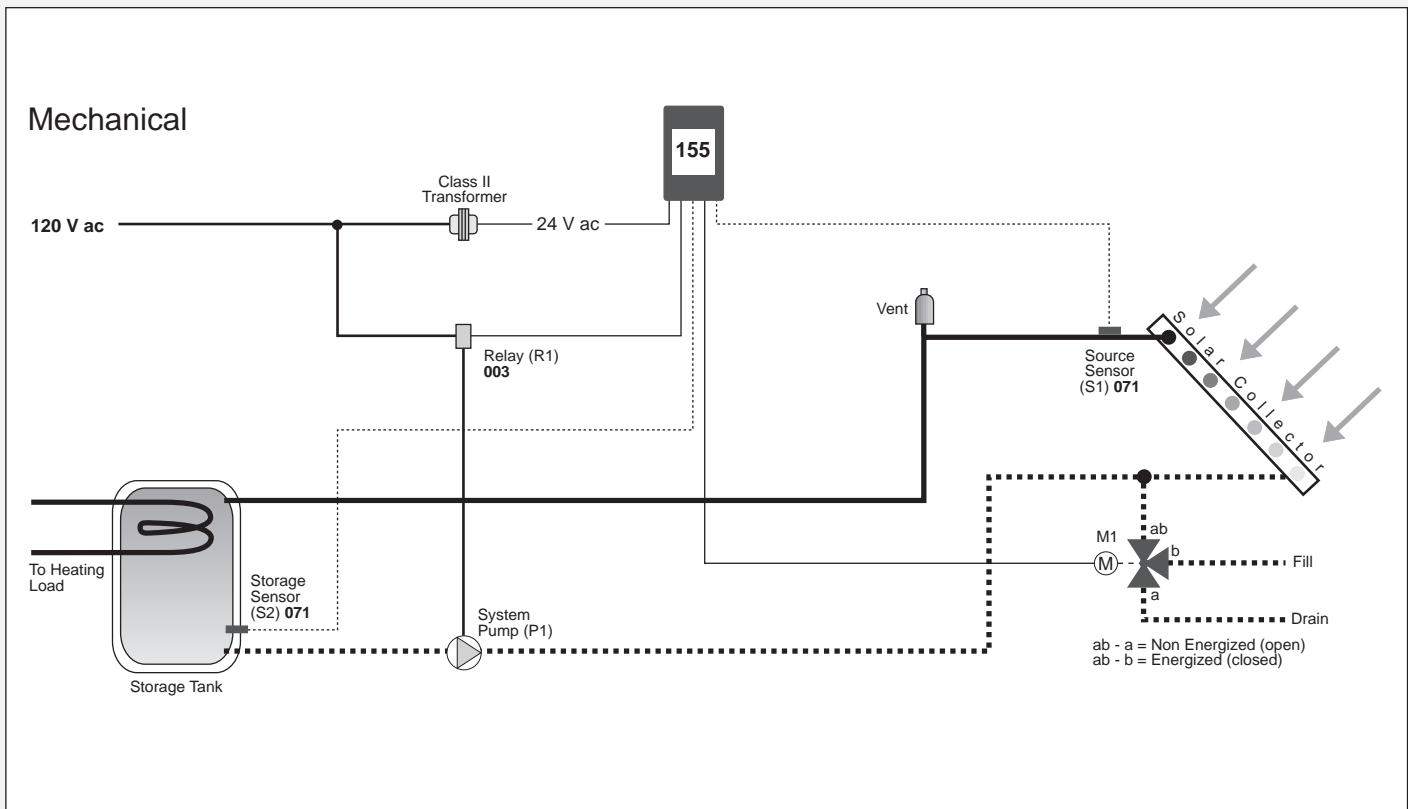

Note: This is only a concept drawing. The designer must determine whether this application will work in his system and must ensure compliance with code requirements. Necessary auxiliary equipment, isolation relays (for loads greater than the specified tekmar internal relay ratings), and other safety and limit devices must be added.

Difference Setpoint Control 155

Literature	— D 155, A 155, D 001, E 000, E 100
Control	— Microprocessor control; This is not a safety (limit) control .
Packaged weight	— 1.0 lb. (450 g), Enclosure C, PVC plastic
Dimensions	— 4-3/4" H x 2-7/8" W x 7/8" D (120 x 74 x 22 mm)
Approvals	— Meets DOC regulations for EMI/RFI.
Ambient conditions	— Indoor use only, -20 to 120°F (-30 to 50°C), < 90% RH non-condensing.
Power supply	— Class 2, 24 V ac ±10% 2 VA OR 30 V dc ±20% 0.03 A
Relays	— 120 V ac 10 A 1/3 hp, pilot duty 240 VA 2A
Sensors	— NTC thermistor, 10 kW @ 25°C ±0.2°C β=3892
included:	Two of Universal Sensor 071.
Control accuracy	— ±0.5°F (±0.25°C) with up to 1000 feet (300m) of 18 AWG wire to sensors.
<i>ΔT Setpoint</i>	— 2 to 90°F (1 to 50°C)
<i>ΔT Differential</i>	— 2 to 45°F (1 to 25°C)
<i>Minimum Source</i>	— -22 to 185°F (-30 to 85°C)
<i>Min. Source Diff'l</i>	— 2 to 45°F (1 to 25°C)
<i>Maximum Storage</i>	— -4 to 248°F (-20 to 120°C)
<i>Max. Storage Diff'l</i>	— 2 to 45°F (1 to 25°C)

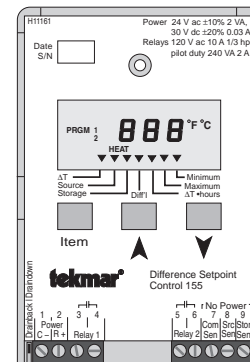

System Operation & Specifications

The tekmar Difference Setpoint Control 155 operates the System Pump whenever the temperature difference between the collector and the storage tank is greater than a ΔT setpoint. The control turns off the pump if the temperature of the storage tank exceeds a maximum setting or if the temperature at the collector drops below a minimum setting. This application utilizes the draindown feature within the control. When the collector temperature drops below a minimum setting, a drain valve is opened to drain the heat transfer fluid from the collector to help prevent freezing. The maximum and minimum temperatures measured at both the collector and the storage tank can be displayed by the control to monitor the system operation. The control can also display the total relative heat transfer from the collector to the storage tank.

The control shall meet the technical specifications listed above and shall provide the following functions.

- A System Pump shall be operated whenever the temperature difference between the collector and the storage tank is greater than a ΔT setpoint.
- The System Pump shall be turned off if the temperature within the storage tank exceeds a maximum setting or the temperature within the collector drops below a minimum setting.
- A drain valve shall be opened whenever the temperature in the collector is below a minimum setting. The control shall have a normally open relay that is energized to close the drain valve. In the event of a power failure, the normally open relay allows the spring return valve to drain the system.
- Some method of refilling the pipes is required once the system is drained. A 3 way valve that can switch the system between the supply (fill) and the drain can be used. Alternatively, the system can be filled manually each time it is drained. A vent is required at the highest point in the system to allow the air to escape while the system is filled.
- The solar collector source sensor shall be located as close as possible to the exit of the collector.
- The storage tank sensor shall be located at the bottom of the tank to ensure an accurate ΔT reading is achieved.
- Adjustable differentials on each of the setpoints shall be provided to prevent short cycling of the pump and drain valve. The setpoints shall be user programmable.
- The control shall display the measured temperatures at both the collector and the storage tank and also display the difference between these temperatures (ΔT). The control shall be able to display the items in both °C and °F.
- The control shall record and display the maximum and minimum temperatures measured at both the collector and the storage tank. The control shall also record and display the $\Delta T \cdot \text{hours}$ of operation such that the energy transfer from the collector to the storage tank can be calculated.
- The control shall continuously monitor the sensors and provide an LCD error message if a sensor or its wiring develops a short or open circuit.
- The installer must ensure that the control and its wiring are isolated and/or shielded from strong sources of electromagnetic noise.
- **Order the following components for this application:** one Difference Setpoint Control 155 and one Relay 003.

In North America:	tekmar Control Systems Ltd., Canada tekmar Control Systems, Inc., U.S.A. Head Office: 4611 - 23rd Street Vernon, B.C. Canada V1T 4K7 Tel. (604) 545-7749 Fax. (604) 545-0650
--------------------------	--

tekmar® - Application

Difference Setpoint Control 155

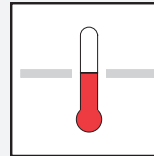

A 155-2

09/94

Mechanical

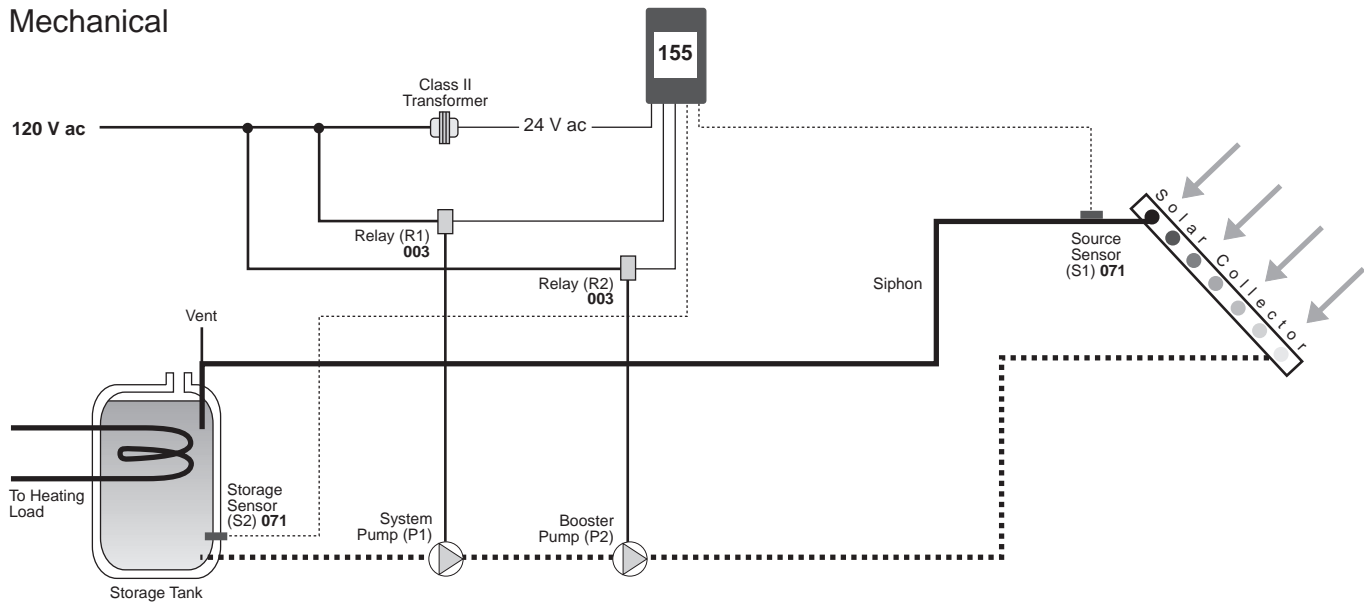

Electrical

P1 = System Pump
 P2 = Booster Pump
 R1, R2 = Relay 003
 S1 = Source Sensor 071
 S2 = Storage Sensor 071

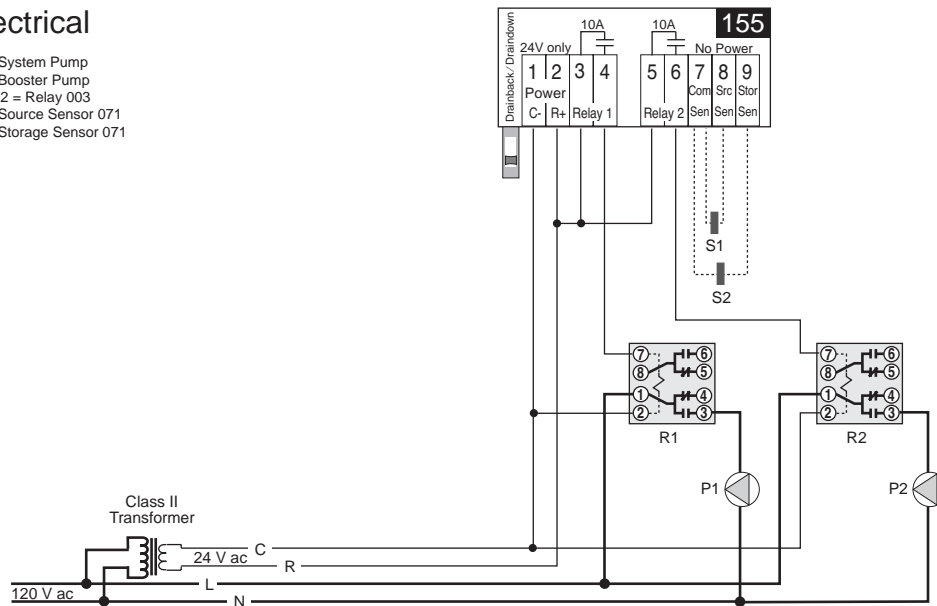

Note: This is only a concept drawing. The designer must determine whether this application will work in his system and must ensure compliance with code requirements. Necessary auxiliary equipment, isolation relays (for loads greater than the specified tekmar internal relay ratings), and other safety and limit devices must be added.

Difference Setpoint Control 155

Literature	— D 155, A 155, D 001, E 000, E 100
Control	— Microprocessor control; This is not a safety (limit) control .
Packaged weight	— 1.0 lb. (450 g), Enclosure C, PVC plastic
Dimensions	— 4-3/4" H x 2-7/8" W x 7/8" D (120 x 74 x 22 mm)
Approvals	— Meets DOC regulations for EMI/RFI.
Ambient conditions	— Indoor use only, -20 to 120°F (-30 to 50°C), < 90% RH non-condensing.
Power supply	— Class 2, 24 V ac ±10% 2 VA OR 30 V dc ±20% 0.03 A
Relays	— 120 V ac 10 A 1/3 hp, pilot duty 240 VA 2A
Sensors	— NTC thermistor, 10 kW @ 25°C ±0.2°C β=3892
included:	Two of Universal Sensor 071.
Control accuracy	— ±0.5°F (±0.25°C) with up to 1000 feet (300m) of 18 AWG wire to sensors.

<i>ΔT Setpoint</i>	— 2 to 90°F (1 to 50°C)
<i>ΔT Differential</i>	— 2 to 45°F (1 to 25°C)
<i>Minimum Source</i>	— -22 to 185°F (-30 to 85°C)
<i>Min. Source Diff'l</i>	— 2 to 45°F (1 to 25°C)
<i>Maximum Storage</i>	— -4 to 248°F (-20 to 120°C)
<i>Max. Storage Diff'l</i>	— 2 to 45°F (1 to 25°C)

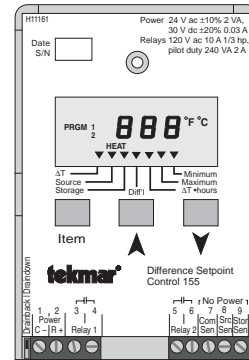

System Operation & Specifications

The tekmar Difference Setpoint Control 155 operates a System Pump whenever the temperature difference between the solar collector and the storage tank is greater than a ΔT setpoint. The control turns off the pump if the temperature of the storage tank exceeds a maximum setting or if the temperature at the collector drops below a minimum setting. This application utilizes the drainback feature within the control. When the System Pump is turned off, the heat transfer fluid drains back from the collector into the storage tank. In order to overcome gravity head and prime the siphon, an additional Booster Pump is operated for 3 minutes when the System Pump is turned on again. The maximum and minimum temperatures measured at both the collector and the storage tank can be displayed by the control to monitor the system operation. The control can also display the total heat transferred from the collector to the storage tank.

The control shall meet the technical specifications listed above and shall provide the following functions.

- A System Pump shall be operated whenever the temperature difference between the collector and the storage tank is greater than a ΔT setpoint.
- The pump shall be turned off if the temperature within the storage tank exceeds a maximum setting or the temperature within the collector drops below a minimum setting.
- The Booster Pump shall be operated for 3 minutes whenever the System Pump is turned on. The Booster Pump should be of sufficient size to overcome the system gravity head and prime the siphon.
- The collector sensor shall be located as close as possible to the exit of the collector.
- The storage tank sensor shall be located at the bottom of the tank to ensure an accurate ΔT reading is achieved.
- Adjustable differentials on each of the setpoints shall be provided to prevent short cycling of the pumps. The setpoints shall be user programmable.
- The control shall display the measured temperatures at both the collector and the storage tank and also display the difference between these temperatures (ΔT). The control shall be able to display the items in both °C and °F.
- The control shall record and display the maximum and minimum temperatures measured at both the collector and the storage tank. The control shall also record and display the ΔT -hours of operation such that the energy transfer from the collector to the storage tank can be calculated.
- The control shall continuously monitor the sensors and provide an LCD error message if a sensor or its wiring develops a short or open circuit.
- The installer must ensure that the control and its wiring are isolated and/or shielded from strong sources of electromagnetic noise.
- **Order the following components for this application:** one Difference Setpoint Control 155 and two of Relay 003.

<p>In North America:</p>	<p>tekmar Control Systems Ltd., Canada tekmar Control Systems, Inc., U.S.A. Head Office: 4611 - 23rd Street Vernon, B.C. Canada V1T 4K7 Tel. (604) 545-7749 Fax. (604) 545-0650</p>
---------------------------------	---

tekmar® - Application

Difference Setpoint Control 155

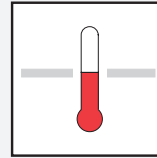

A 155-3

09/94

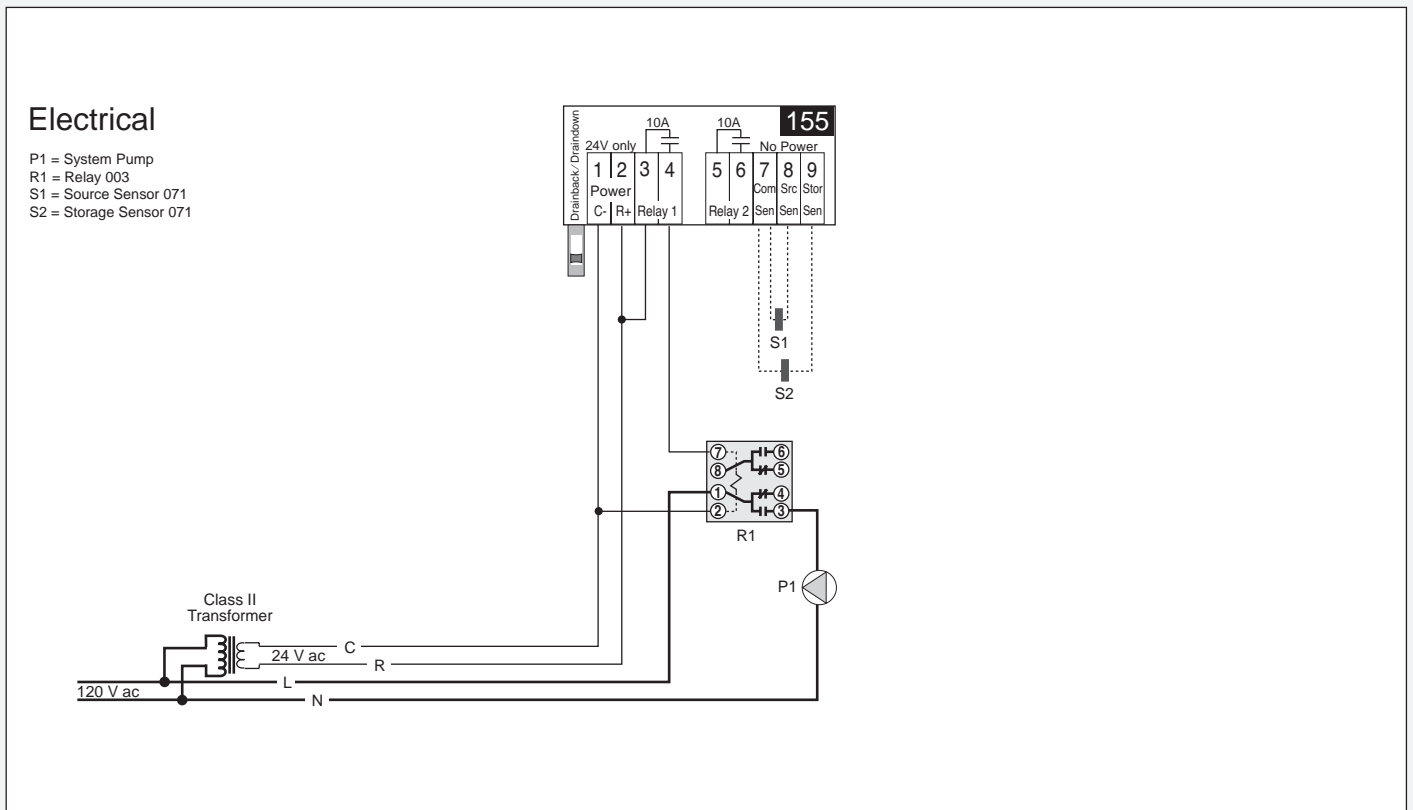
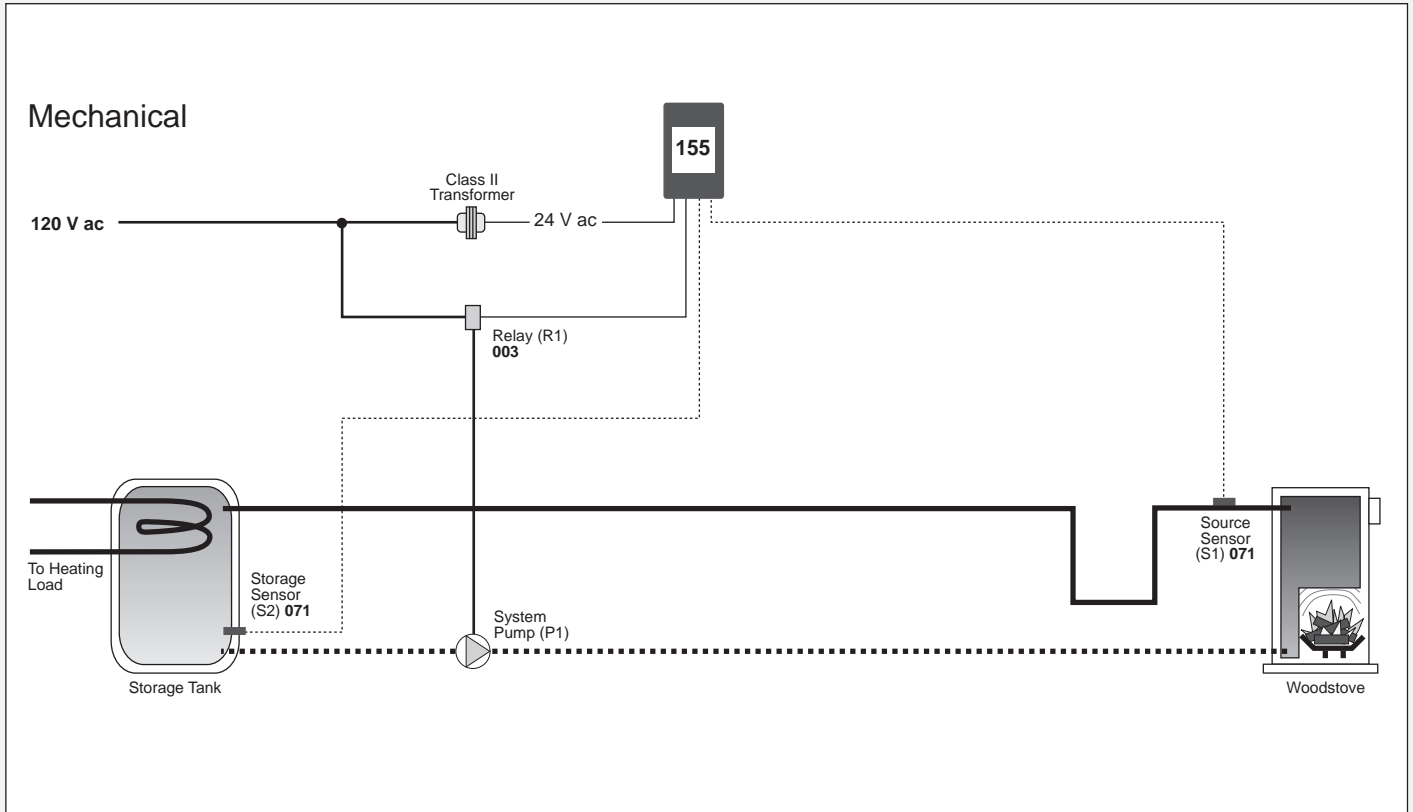

Note: This is only a concept drawing. The designer must determine whether this application will work in his system and must ensure compliance with code requirements. Necessary auxiliary equipment, isolation relays (for loads greater than the specified tekmar internal relay ratings), and other safety and limit devices must be added.

Difference Setpoint Control 155

Literature	— D 155, A 155, D 001, E 000, E 100
Control	— Microprocessor control; This is not a safety (limit) control .
Packaged weight	— 1.0 lb. (450 g), Enclosure C, PVC plastic
Dimensions	— 4-3/4" H x 2-7/8" W x 7/8" D (120 x 74 x 22 mm)
Approvals	— Meets DOC regulations for EMI/RFI.
Ambient conditions	— Indoor use only, -20 to 120°F (-30 to 50°C), < 90% RH non-condensing.
Power supply	— Class 2, 24 V ac ±10% 2 VA OR 30 V dc ±20% 0.03 A
Relays	— 120 V ac 10 A 1/3 hp, pilot duty 240 VA 2A
Sensors included:	— NTC thermistor, 10 kW @ 25°C ±0.2°C β=3892 Two of Universal Sensor 071.
Control accuracy	— ±0.5°F (±0.25°C) with up to 1000 feet (300m) of 18 AWG wire to sensors.
<i>ΔT Setpoint</i>	— 2 to 90°F (1 to 50°C)
<i>ΔT Differential</i>	— 2 to 45°F (1 to 25°C)
<i>Minimum Source</i>	— -22 to 185°F (-30 to 85°C)
<i>Min. Source Diff'l</i>	— 2 to 45°F (1 to 25°C)
<i>Maximum Storage</i>	— -4 to 248°F (-20 to 120°C)
<i>Max. Storage Diff'l</i>	— 2 to 45°F (1 to 25°C)

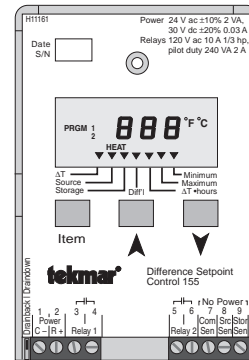

System Operation & Specifications

The tekmar Difference Setpoint Control 155 operates a System Pump whenever the temperature difference between the woodstove (source) and the storage tank is greater than a ΔT setpoint. The maximum and minimum temperatures measured at both the wood stove and the storage tank can be displayed by the control to monitor the system operation. The control can also display the total heat transferred from the stove to the storage tank.

The control shall meet the technical specifications listed above and shall provide the following functions.

- A System Pump shall be operated whenever the temperature difference between the wood stove and the storage tank is greater than a ΔT setpoint.
- The pump shall be turned off if the temperature within the storage tank exceeds a maximum setting.
- The woodstove source sensor shall be located on the exit of the stove and the storage tank sensor shall be located at the bottom of the tank to ensure an accurate ΔT reading is achieved.
- Adjustable differentials on each of the setpoints shall be provided to prevent short cycling of the pump. The setpoints shall be user programmable.
- The control shall display the measured temperatures at both the stove and the storage tank and also display the difference between these temperatures (ΔT). The control shall be able to display the items in both °C and °F.
- The control shall record and display the maximum and minimum temperatures measured at both the stove and the storage tank. The control shall also record and display the $\Delta T \cdot \text{hours}$ of operation such that the energy transfer from the stove to the storage tank can be calculated.
- The control shall continuously monitor the sensors and provide an LCD error message if a sensor or its wiring develops a short or open circuit.
- The installer must ensure that the control and its wiring are isolated and/or shielded from strong sources of electromagnetic noise.
- **Order the following components for this application:** one Difference Setpoint Control 155 and one Relay 003.

In North America:	tekmar Control Systems Ltd., Canada tekmar Control Systems, Inc., U.S.A. Head Office: 4611 - 23rd Street Vernon, B.C. Canada V1T 4K7 Tel. (604) 545-7749 Fax. (604) 545-0650
--------------------------	--